

## Set-Education For An Information/Knowledge Economy In Nigeria: Policy Issues And Challenges

Engr. Prof. J.N. Ofulue, Ph.D,

“Centre For Informatics and Technology Innovation”

(A Division Of Infotel Ltd)

Wellspring University, Benin City.

---

### ABSTRACT

This paper reviews the present Technical Education in Nigeria and identifies its non-relevance to the demands of Information Economy skills in Business, Education and Government. The rigid structure and akaic CONTENT of the Education system in Nigeria need to be urgently reviewed and reformed. Besides, technology infrastructure, IT skills are almost non-existent. And for us to catch the moving Technology train and bridge the Education gap, a surgical or a break away from the past Attitude / Mindset must be initiated. It is concluded that Technical Education for-all-policy must be implemented and also to include continuing teacher education and reward system (STEMS Strategy) Sectorial Skill Analysis requirements must be carried out by the Manpower Board to guide admissions requirements into Secondary/Tertiary institutions. This is the only way we can meet the demands of the Information/Knowledge economy in the 21<sup>st</sup> century.

**Keywords:** Education, Technical Education, Technology Acquisition, Indigenous Education Policy, & Stems Strategy

---

### INTRODUCTION

During the past three decades, IT/Telecommunications have undergone spectacular technological and structural changes, having few comparisons in others areas. Together with digital technology, they form the engine to the massive shift towards the Information economy (or even Society) which is now taking place. The Information/Knowledge society already in Europe and America, will accelerate over the next few decades, giving rise to far reaching changes in industry, education and society values.

Information will be the key to success in the 21<sup>st</sup> century. Its technology, Information Technology, will be vehicle of the economy. Whether at work or at national levels, the more information we have at our finger tips, the further we can see and plan. Hence the competition among nations to control the Information economy. (Internet Control).

The Education industry is a key part of the Information industry. In most developed and developing countries of the world, this is identified as a strategic industry not only because of the size of its out put-in several European and US countries where the Education industry forms one of the largest economic sectors – but also because of its effects on other sectors of the economy. Telecommunications have for a long time played an important role in industries and commerce. In recent years (1980 upwards) the importance of this role has grown vastly owing to the increasing power of Internet and the

applications of Artificial Intelligence (AI Technology) and new Marketing and Management practices. Hence, IT is becoming a part of practically all economic activity.

As a result of the increasing coverage of Telecommunication and Computer (including software) technologies, there is a strong tendency towards integration in terms of acquisitions, joint ventures etc., between Telecommunications, Computer, Semi conductor and software enterprises.

When analyzing the structural changes taking place in the IT industry, special attention must be paid to an event in US when in 1984, the deregulation of AT&T, the world's largest telecoms market, representing then forty percent of the world market, was opened to National and International competition and AT & T was free to engage in business activities, in particular COMPUTING in addition to telecommunications. United Kingdom followed with the British Telecommunications Act of 1984. At the same time in some market-economy countries, the PTT (Post, Telegraph and Telephone Companies), have preserved their monopoly but diminished the types of services they provide.

Nigeria's economic plans should provide the basic needs of her people i.e. Food, Housing, Education, Health And Leisure. These are products of integrated industry development processes for a people. Information technology provides the integrating element (Carrier) for all the industry, commerce and

administration. Consequently, the National plans should integrate the policy and strategy for Information Technology to support the other political, economic and social vision. This includes IT Education, IT Research & Development and Innovations.

*“Information will be the key to success in the 21<sup>st</sup> century. Its technology, information technology, will be vehicle of the economy. Whether at work or at national levels, the more information we have at our finger tips the more in the future we can see and plan”.*

Nigeria is part of the global society and the world society is becoming an information society or economy. IT infrastructure therefore should help to improve human-relations. Communication is basic to human relationships. IT infrastructure is basic in generation, collection and transmission of information for effective decision-making. This is Figure 1

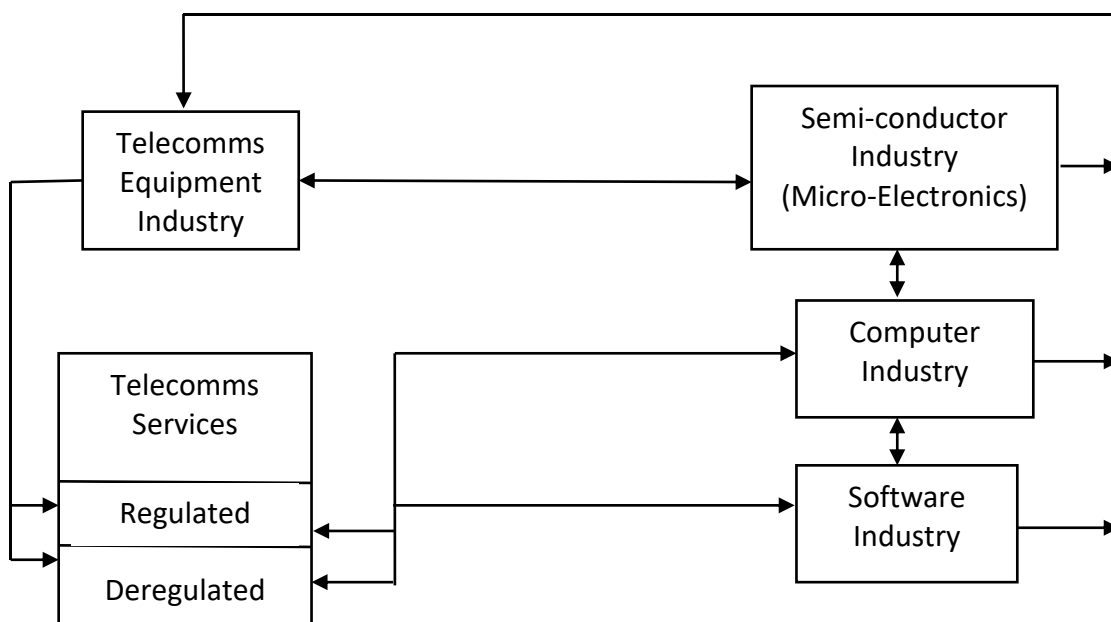

Figure 1: Integration between Branches of the information Technology Industry

**ENGINEERING EDUCATION IN NIGERIA:A Case Study**

Generally what is Education? The word “Educate” has its roots in the Latin word “educio”, which means to develop from within, to educe, to draw out, to grow through use. But there has long been a general misconception of the meaning of the word “Educate” as an act of “imparting knowledge”. Knowledge grows out of organized information. It grows out of it through application and use.

“An educated person is one who knows how to acquire everything he needs in the attainment of his

where Information Technology (information processing, transmission, security and storage) plays a vital role in the interaction between man and his environment. Most industrial and human activities in the environment involve man moving data about and carrying out calculations on them whether compiling records or sensors, studying the environment, forecasting or taking management decision. In addition, fast secured transport of the information becomes necessary to win wars or competition. The activities are now beyond what man can do. Hence the urgent need for Integrated Information Infrastructure. IT will change our ways of life, Education, Health, Agriculture, Marketing, Transport, Human Relations, even the environment etc; only relevant education structure and content can facilitate these. Hence the need to restructure our education system for STEMS (Science, Technology, Entrepreneurship, and Manufacture Systems).

main purpose in life, without violating the rights of his fellow men” (Napoleon Hill).

Which of the above definition does our education system conform with?

Obviously, it is only an act of importing knowledge out of unorganized information with no target use; I leave the rest to the specialist Educationists on Nigeria.

Engineering Education is about developing inert abilities for use by would be engineers. Engineering is a profession concerned with the creation of new and improved systems, processes and products, to serve human needs as they are expressed by individuals, communities, government and society at

large. Our present engineering education system in Nigeria cannot fulfill above aspiration for the global information economy empowerment. Considering, for example, the National University Commission (NUC) common minimum academic standards for Engineering, the philosophy is still relevant, but the goals/objectives cannot be realized because of the contents of engineering education and implementation strategy adopted. The system produces electronics/computer engineers who cannot write a line of Assembly Language programs or identify the major parts of a computer system. Both the professional teacher engineers and the computer system laboratory are not equipped to facilitate engineering education. Most conspicuously absent are engineering economics, engineering management, engineering law, which are the elements binding the engineering profession to society.

After graduation, the engineer in Nigeria has no formal institution for continuing education, especially in Hitech areas like Information technology. Continuing education of engineers must be pursued seriously especially for updating and upgrading of knowledge, which decays every three years in the knowledge economy. I call on Nigeria Society of Engineers and COREN to do something urgently on this issue, or the future of Engineering Profession in Nigeria will not be guaranteed.

#### DEMANDS OF INFORMATION ECONOMY

Information economy demands Knowledge Workers. The Professional in the information economy must therefore be proactive and knowledgeable. He must be a 'system' man, as there would be no room for subject Experts, **especially in the decades of SMART Everything (IoT)**

Information economy demands knowledge engineers with systematic view of the global networks. Intensive research and development in Innovative Technologies will be the catalyst to information economy development. Therefore qualitative technical education is the potent weapon for the development of man and his society. Hence in USA and Europe over 15% of their GDP is devoted to investment in technological development especially for the information infrastructure facilities. **Consequently we must retrace our steps in the faculty planning of our technical educational curricula which is now out of tune with the demands of information economy.** The basic sciences like Chemistry and Biochemistry should be de-emphasized in our tertiary institutions in favour of the technical sciences and technological innovation programmes.

#### CONCLUSIONS AND RECOMMENDATIONS

Most of the old-bread professionals are IT illiterate and majority of the population in Nigeria are also IT

illiterate. In addition, there is no effective IT infrastructure or industry. At this Zero point we must concentrate on massive education and skills training of our Nigerian people (people-ware);

Through-

- Effective National Education for all policy at all levels.
- Massive Teacher education programme at all levels;
- Formal Continuing Technical Education Centers (CTEC) by Universities/Polytechnics.
- Sectorial Skill Analysis requirements programme by the Manpower Board of Governments;
- Review National education curricula and structure in collaboration with established industries in various sectors of the economy: STEMS!
- Mobilization of the Nigerian people towards Technology development programmes like in India, Korea and Canadian Innovation Models OR **(BSI-Model)**
- We must embrace technology **that is adaptable within our cultural values**, as users of such technology have basic cultural and traditional values which cannot easily be eliminated;
- Lastly and most important; our educational goal must be based on the philosophy of **leadership, creative problem solving, culture and digital innovation.**

#### REFERENCES

- ENGR. FALUYI, A.O. The making of an Engineer – The Nigerian Experience” 12<sup>th</sup> October, lecture, 1993.
- Engr. Dr. J.N. Ofulue “Strategy for Telecom.Manpower Development in Nigeria” Invited paper from Ministry of Communications seminar on Telecommunication Policy for Nigeria, July 1999.
- “The imperatives of Engineering Management and Technology in the Global Economic Recession” By Engr. Prof. Ofulue J.N. (Speaker) @ NSE –AGM & Conference, Asaba Branch, Oct, 2009, ASABA.
- Federal Rep. of Nigeria. National Policy on Education, Dept., of information Publication, 1990; 2013 with 4 years strategic plan.
- National Universities Commission Common Minimum Academics standards for Engineering. (2006)
- COREN Decree No. 27, 1992; Amended ACTS 110/CAPEII
- National Sciences, Technology and Innovation (ST&I) POLICY, FMST 2012.